

## OVERVIEW OF THE ROLE OF THE NATIONAL BUILDING CONTROL & MARKET SURVEILLANCE OFFICE

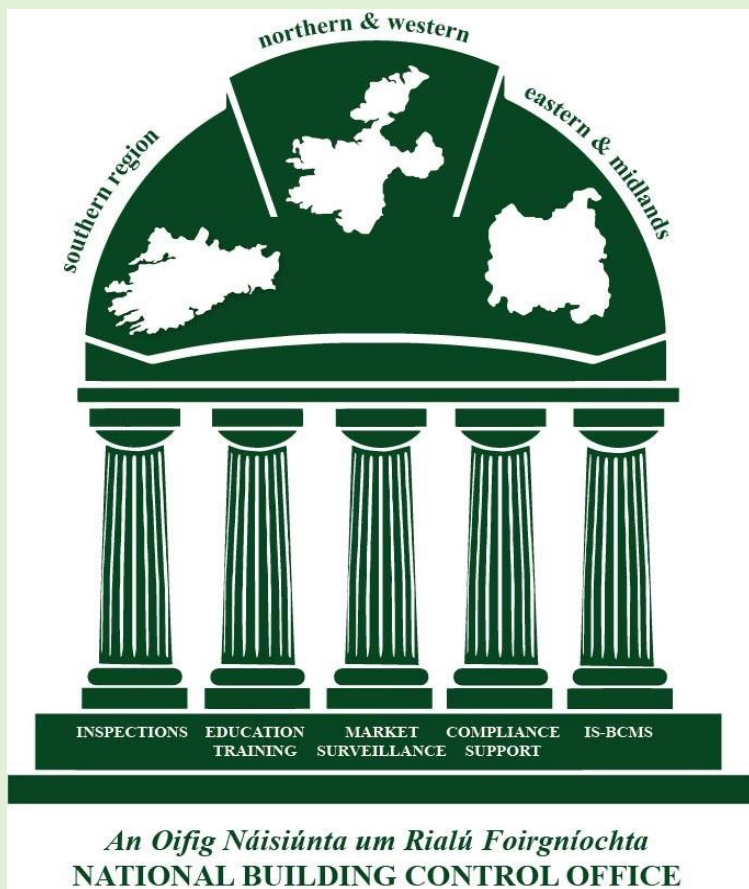

**Working with Economic Operators**  
(Manufacturers, Importers, Distributors & Authorised Representatives)  
**to Promote a Culture of Compliance with the**  
**Construction Products Regulation**  
**(EU) No. 305/2011**

# Market Surveillance of Construction Products Legislative Framework

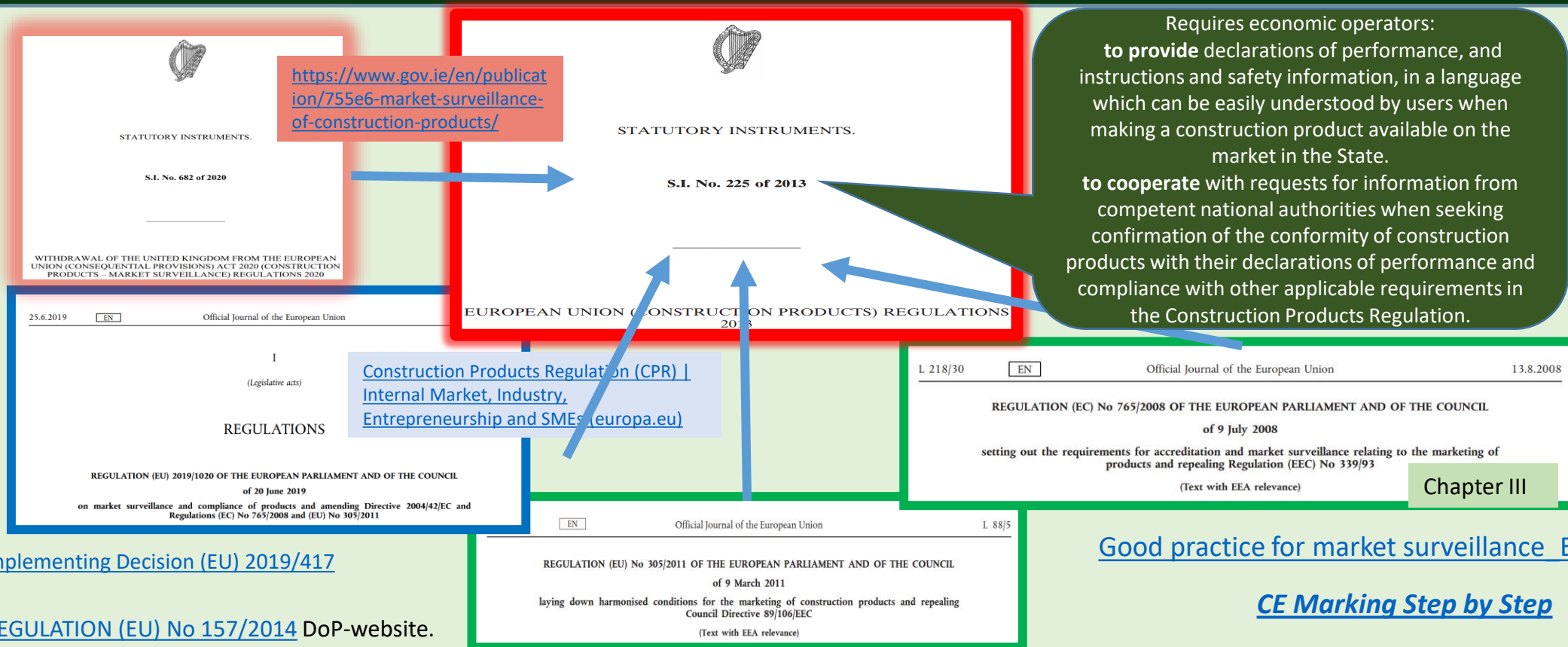

[Commission Implementing Decision \(EU\) 2019/417](#)  
RAPEX

[DELEGATED REGULATION \(EU\) No 157/2014](#) DoP-website.  
[DELEGATED REGULATION \(EU\) No 574/2014](#) of 21 February  
2014 amending Annex III -drawing up a DoP.

[BRAB Information Note on the CPR](#)

[Good practice for market surveillance EN MSAs](#)

[CE Marking Step by Step](#)

[Risk assessment. Market surveillance, construction products](#)

[Guidelines for Market Surveillance Authorities 2016](#)

[https://ec.europa.eu/growth/sectors/construction/construction-products-regulation-cpr\\_en](https://ec.europa.eu/growth/sectors/construction/construction-products-regulation-cpr_en)

## Construction Products Regulation & Market Surveillance and Compliance of Products

[The “[Construction Products Regulation](#)”

[EU 305 of 2011](#), prescribes **BASIC REQUIREMENTS FOR CONSTRUCTION WORKS** i.e.,

*Construction works as a whole and in their separate parts must be fit for their intended use, considering in particular the health and safety of persons involved throughout the life cycle of the works. Subject to normal maintenance, construction works must satisfy these basic requirements for construction works for an economically reasonable working life.”]*

*‘essential characteristics’ means those characteristics of the construction product which relate to the basic requirements for construction works;*



Article 18(5) Regulation (EC) 765/2008, Ireland’s [National market surveillance programme 2021](#)  
Article 13 Regulation 2019/1020 Ireland’s [National Market Surveillance Strategy 2022 - July 2022 & Market Surveillance of Construction Products Strategy 2023 - Ireland](#)

[The “[Market Surveillance & Compliance of Products Regulations](#)”

[EU 2019 of 1020](#) “**market surveillance**” means the activities carried out and measures taken by market surveillance authorities to ensure that products comply with the requirements set out in the applicable Union harmonisation legislation and to ensure protection of the public interest covered by that legislation”]

# REGULATION (EU) No 305/2011



- *The primary purpose of the Construction Products Regulation is to break down technical barriers to trade to ensure the free movement of construction products across Member States within the European Union*

# Regulation EU 2019/1020 on Market Surveillance & Compliance of Products

## Article 1 (Annex 1 List of 70 Union harmonisation legislation CPR -No 38 on list)

### GENERAL PROVISIONS

#### Article 1

#### Subject matter

1. *The objective of this Regulation is to improve the functioning of the internal market by strengthening the market surveillance of products covered by the Union harmonisation legislation referred to in Article 2, with a view to ensuring that only compliant products that fulfil requirements providing a high level of protection of public interests, such as health and safety in general, health and safety in the workplace, the protection of consumers, the protection of the environment and public security and any other public interests protected by that legislation, are made available on the Union market.*

2. *This Regulation lays down rules and procedures for economic operators regarding products subject to certain Union harmonisation legislation and establishes a framework for cooperation with economic operators.*

3. *This Regulation also provides a framework for controls on products entering the Union market.*



# REGULATION (EU) No 305/2011 – Article 2 & ANNEX IV – Table 1 PRODUCT AREAS

‘**Economic Operator**’ means the manufacturer, importer, distributor or authorised representative;  
 ‘**Construction Product**’ means any product or kit which is produced and placed on the market for incorporation in a permanent manner in construction works or parts thereof and the performance of which has an effect on the performance of the construction works with respect to the basic requirements for construction works;

The **CE marking** should be affixed to all construction products for which the manufacturer has drawn up a declaration of performance in accordance with this Regulation.

- If a **declaration of performance** has not been drawn up, the CE marking should not be affixed.

## PRODUCT AREAS -ANNEX IV –Regulation 305 of 2011

CODE	PRODUCT AREA
1	PRECAST NORMAL/LIGHTWEIGHT/AUTOCLAVED AERATED CONCRETE PRODUCTS.
2	DOORS, WINDOWS, SHUTTERS, GATES AND RELATED BUILDING HARDWARE.
3	MEMBRANES, INCLUDING LIQUID APPLIED AND KITS (FOR WATER AND/OR WATER VAPOUR CONTROL).
4	THERMAL INSULATION PRODUCTS. COMPOSITE INSULATING KITS/SYSTEMS.
5	STRUCTURAL BEARINGS. PINS FOR STRUCTURAL JOINTS.
6	CHIMNEYS, FLUES AND SPECIFIC PRODUCTS.
7	GYPSUM PRODUCTS.
8	GEOTEXTILES, GEOMEMBRANES, AND RELATED PRODUCTS.
9	CURTAIN WALLING/CLADDING/STRUCTURAL SEALANT GLAZING.
10	FIXED FIRE FIGHTING EQUIPMENT (FIRE ALARM/DETECTION, FIXED FIREFIGHTING, FIRE AND SMOKE CONTROL AND EXPLOSION SUPPRESSION PRODUCT).
11	SANITARY APPLIANCES.
12	CIRCULATION FIXTURES: ROAD EQUIPMENT.
13	STRUCTURAL TIMBER PRODUCTS/ELEMENTS AND ANCILLARIES.
14	WOOD BASED PANELS AND ELEMENTS.
15	CEMENT, BUILDING LIMES AND OTHER HYDRAULIC BINDERS.
16	REINFORCING AND PRESTRESSING STEEL FOR CONCRETE (AND ANCILLARIES). POST TENSIONING KITS.
17	MASONRY AND RELATED PRODUCTS. MASONRY UNITS, MORTARS, AND ANCILLARIES.
18	WASTE WATER ENGINEERING PRODUCTS.
19	FLOORINGS.
20	STRUCTURAL METALLIC PRODUCTS AND ANCILLARIES.
21	INTERNAL & EXTERNAL WALL AND CEILING FINISHES. INTERNAL PARTITION KITS.
22	ROOF COVERINGS, ROOF LIGHTS, ROOF WINDOWS, AND ANCILLARY PRODUCTS. ROOF KITS.
23	ROAD CONSTRUCTION PRODUCTS.
24	AGGREGATES.
25	CONSTRUCTION ADHESIVES.
26	PRODUCTS RELATED TO CONCRETE, MORTAR AND GROUT.
27	SPACE HEATING APPLIANCES.
28	PIPES-TANKS AND ANCILLARIES NOT IN CONTACT WITH WATER INTENDED FOR HUMAN CONSUMPTION.
29	CONSTRUCTION PRODUCTS IN CONTACT WITH WATER INTENDED FOR HUMAN CONSUMPTION.
30	FLAT GLASS, PROFILED GLASS AND GLASS BLOCK PRODUCTS.
31	POWER, CONTROL AND COMMUNICATION CABLES.
32	SEALANTS FOR JOINTS.
33	FIXINGS.
34	BUILDING KITS, UNITS, AND PREFABRICATED ELEMENTS.
35	FIRE STOPPING, FIRE SEALING AND FIRE PROTECTIVE PRODUCTS. FIRE RETARDANT PRODUCTS.



# Market Surveillance Hierarchy, MSAs Ireland EU 2016



European Commission



AdCo

*Article 10 Each Member State shall appoint a single liaison office CCPC*

CCPC

Single Liaison Office  
National MS Strategy

National Market Surveillance Office

National Market Surveillance of Construction Products Strategy

TII & GSI Competent National Authorities  
(Area Codes, 12, 23, 24)

31 Market Surveillance Authorities

Strategic Objectives

Detailed Proposals

Single Liaison Office represents the coordinated position of the MSR 2019/1020 EU ANNEX I List of 70 Union harmonisation legislation requirements on products to protect consumers, health and safety, the environment and other public interests.



Manufacturer selects an EU based NB, if needed, CE mark | Accredits the CAB/NB | Appoints the NB | NB listed on NANDO databased for specific products | Monitor products on the EU market

## CHAPTER III OBLIGATIONS OF ECONOMIC OPERATORS

### Obligations of Manufacturers –Distributers – Retailers –Authorised Representatives

Place on the Union market only construction products which are compliant with the applicable requirements of CPR.

- **Article 11 Obligations of manufacturers**
- **Article 12 Authorised representatives**
- **Article 13 Obligations of importers**
- **Article 14 Obligations of distributors**

Ensure the assessment and the verification of constancy of performance AVCP.

- Declaration of performance in
- CE marking,
- Safety Information in Use-language which can be easily understood by users.

- **shall keep** the technical documentation and the declaration of performance for a period of 10 years after the construction product has been placed on the market.
- **shall ensure** that procedures are in place to ensure that series production maintains the declared performance (Factory Production Control (FPC))
  - carry out sample testing
  - Investigate
  - keep a register; complaints, non-conforming products; recalls, keep distributors informed of monitoring.
- **shall ensure** construction products bear a type, batch or serial number or other identifying, .name, registered trade name & mark, contact address, contact point.
- Reason to believe not in **conformity-recall, corrective action** & inform MSA.
- Comply with reasoned **requests from MSA**



## Compliance Assessment –Responsibility



**ECONOMIC OPERATOR** -It is the Economic Operators responsibility, according to their respective role in the supply chain, to ensure compliance with all relevant legislation and to fulfil all appropriate conformity assessment obligations.

**MARKET SURVEILLANCE AUTHORITY** -The task of the Market Surveillance Authority is to **verify** whether a product complies with the requirements of the applicable legislation.

**Market Surveillance Authority should not issue a compliance statement which could be seen as endorsing a product.**

<https://ec.europa.eu/docsroom/documents/23041>

[Good Practice for Market Surveillance](#)



A-Z Index | Sitemap | About this site | FAQ | What's new | Legal notice | Contact | Search | English (en)

EUROPEAN COMMISSION

European Commission > DocsRoom > Document detail

**Good practice for market surveillance**

Document date: 05/05/2017 - Created by GROW.DG1.B.1 - Publication date: 06/05/2017

Download links:  
[Good practice for market surveillance](#) (2 MB)

Share

Stay connected

Facebook Google+ Twitter EU Tube

## Declaration of Performance Articles 4, 5, 6,7

ANNEX III 305/2011-amended by

[COMMISSION DELEGATED REGULATION \(EU\) No 574/2014 of 21 February 2014](#)

'DECLARATION OF PERFORMANCE No

1. **Unique identification code of the product-type:**

2. **Intended use/es:**

3. **Manufacturer:**

4. **Authorised representative:**

5. **System/s of AVCP:**

6a. **Harmonised standard:**

Notified body/ies:

6b. **European Assessment Document:**

European Technical Assessment:

Technical Assessment Body:

Notified body/ies:

7. **Declared performance/**

8. **Appropriate Technical Documentation and/or Specific Technical Documentation:**

The performance of the product identified above is in conformity with the set of declared performance/s. This declaration of performance is issued, in accordance with Regulation (EU) No 305/2011, under the sole responsibility of the manufacturer identified above.

**Signed for and on behalf of the manufacturer by:**

Signed for and on behalf of the manufacturer by:

[name]

A [place] on [date of issue]

[signature]

Article 7-A copy of the declaration of performance of each product which is made available on the market shall be supplied either in paper form or by electronic means.

## Articles 8 & 9 Regulation 305/2011- CE Marking-& Extract from:

<https://ec.europa.eu/docsroom/documents/12308/attachments/1/translations/en/renditions/native>

You cannot affix the CE marking until the declaration of performance has been drawn up, usually at the end of the production phase.

	CE symbol
14	last two digits of the year in which CE was first affixed
AnyCo Ltd, PO Box 21, B-1050, City, Country	name and registered address of the manufacturer
12345 - ABCDE - #####	reference number of the DoP (also unique identification code)
EN #####	reference to the harmonised technical specification
Notified Body ###	identification number of the Notified Body
Internal and external use	intended use(s)
Characteristic: ## Characteristic: Class ## Characteristic: #### Characteristic: Class #	level or class of the performance declared
www.anyco-ltd.eu/dop	website hosting the DoP

Article 8-The CE marking shall be affixed to those construction products for which the manufacturer has drawn up a declaration of performance in accordance with Articles 4 and 6

Article 9-The CE marking shall be affixed before the construction product is placed on the market. It may be followed by a pictogram or any other mark notably indicating a special risk or use.

Extract from:

<https://ec.europa.eu/docsroom/documents/12308/attachments/1/translations/en/renditions/native>

## Articles 11, 13, 14 Regulation 305/2011 Instructions and Safety Information

Without prejudice to the requirements of Articles 11 and 12 of the Construction Products Regulation, when making a construction product available on the market, manufacturers/importers/distributors **shall** ensure that the product is accompanied by **instructions and safety information in a language which can be easily understood by users where the product is made available on the market in the State.**

Part 2 of these Regulations requires economic operators to provide declarations of performance, and instructions and safety information, in a language which can be easily understood by users when making a construction product available on the market in the State. Regulation 9 requires economic operators to cooperate with requests for information from competent national authorities when seeking confirmation of the conformity of construction products with their declarations of performance and compliance with other applicable requirements in the Construction Products Regulation.

# REGULATION (EU) No 305/2011 & Regulation 2019/1020 Construction Products, Market Surveillance & Building Control

- **Reg. (EU) No. 305/2011**
  - Remove barriers to trade
  - Conditions which apply when placing a construction product on the market
  - Creates obligations on Economic Operators (EOs)
  - **Does NOT** regulate the use of construction products when incorporated into construction works – covered by Building Regs.

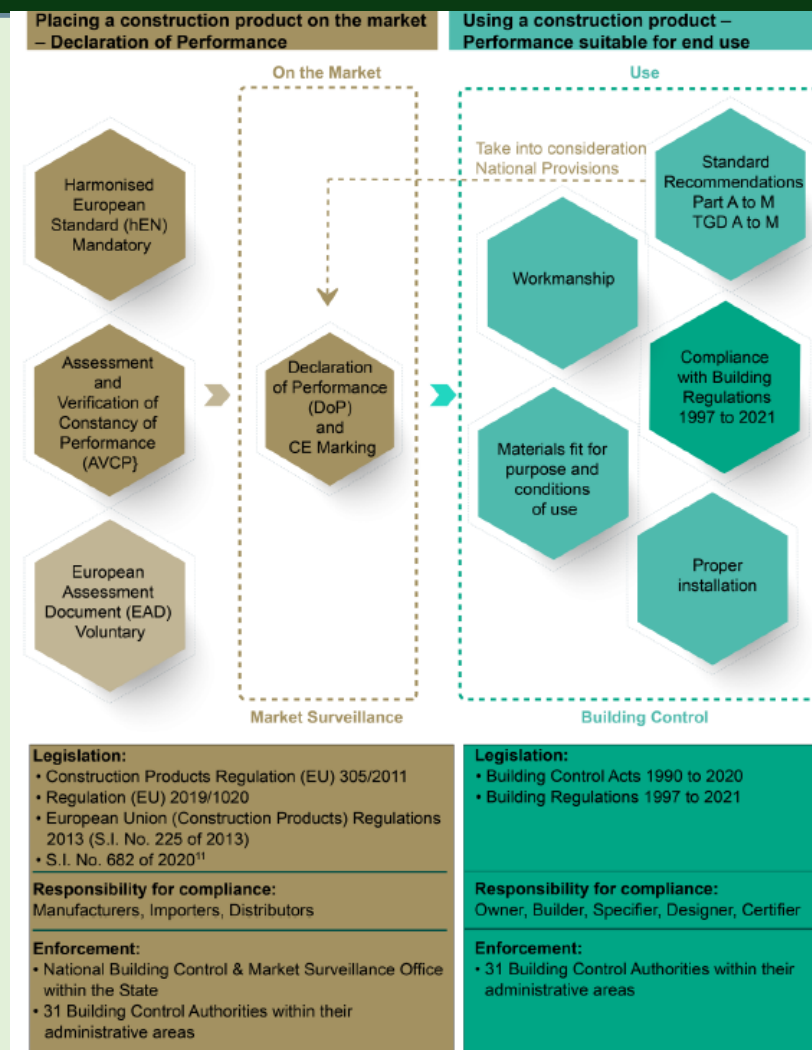

## REGULATION (EU) 2019/1020- Article 11-Activities of Market Surveillance Authorities

Market surveillance authorities, **shall perform** appropriate checks on the characteristics of products on an adequate scale, by **means of documentary** checks and, where appropriate, **physical and laboratory checks** based on adequate samples, **prioritising their resources and actions to ensure effective market surveillance** and taking into account the **national market surveillance strategy** referred to in Article 13.

In deciding on which checks to perform, on which types of products and on what **scale**, market surveillance authorities shall follow a **risk-based approach** taking into account the following factors:

- (a) possible **hazards and non-compliance** associated with the products and, where available, their occurrence on the market;
- (b) **activities and operations under the control** of the economic operator;
- (c) the **economic operator's past record** of non-compliance;
- (d) if relevant, the **risk profiling** performed by the authorities designated under Article 25(1);
- (e) **consumer complaints** and other information received from other authorities, economic operators, media and other sources that might indicate non-compliance.

## Market Surveillance Appointment of Authorised Officers S.I. No. 225 of 2013



- 11 (a) a **Building Control Authority** shall appoint officers to be authorised officers for the purpose of these Regulations,
- (b) a **Competent Authority** appointed by the Minister pursuant to Regulation 10(1)(b) shall appoint officers to be authorised officers for the purpose of these Regulations, or
- (c) a **competent person** appointed by the Minister pursuant to Regulation 10(1)(c) shall be an authorised officer for the purpose of these Regulations.
- (2) An authorised officer **shall be furnished with a warrant of his appointment** as an authorised officer and, when exercising any power conferred on him by these Regulations, shall, if requested by any person affected, produce the warrant to that person.”

*A Market Surveillance Authority may also encourage compliance by providing information on applicable legislation (e.g., via press releases, dedicated websites, or information campaigns) at any stage of the design and production process and carry out checks at trade shows fairs and exhibitions*

# Market Surveillance Authorities & Authorised Officers

- S10 Market surveillance
- S11 Appointment of authorised officers
- S12 Powers of authorised officers
- S13. Warrant to enter and search
- S14. Corrective actions
- S15. Service of notices

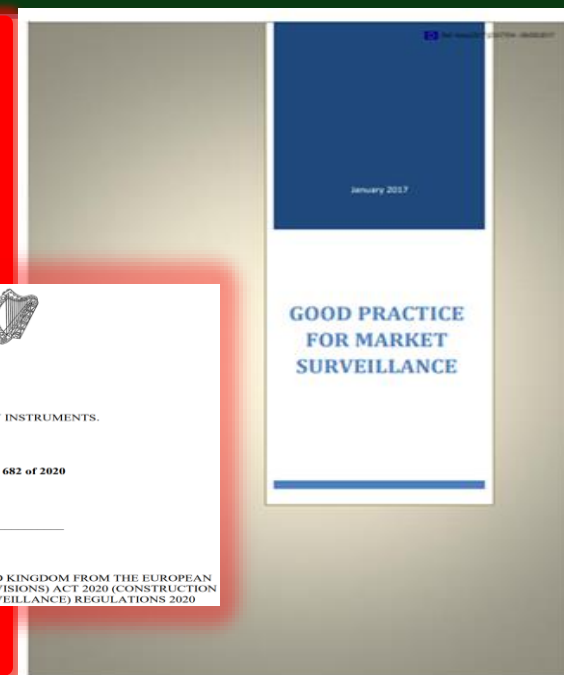

**Inspections**  
**Planned**  
**Reactive**  
**Random**

A004 National Building Control Management Project

**Guidelines for Market Surveillance Authorities**

Date: 6<sup>th</sup> June 2017

Version 1.0  
Prepared by: NBCMP - Compliance Support Working Group  
Signed Mairéad Phelan



Comhairle Leath-Bairistreacha Contae agus Cathrach  
County and City Management Association

COMPETENT NATIONAL AUTHORITY-S.I 225 Of 2013	Product AREA CODE(S)
31 Local Authorities	1-35
National Market Surveillance Office (DCC)	1-35
Geological Survey of Ireland	24
National Roads Authority	12, 23, 24



## Market Surveillance Authorities & Authorised Officers



[Good Practice for Market Surveillance](#)

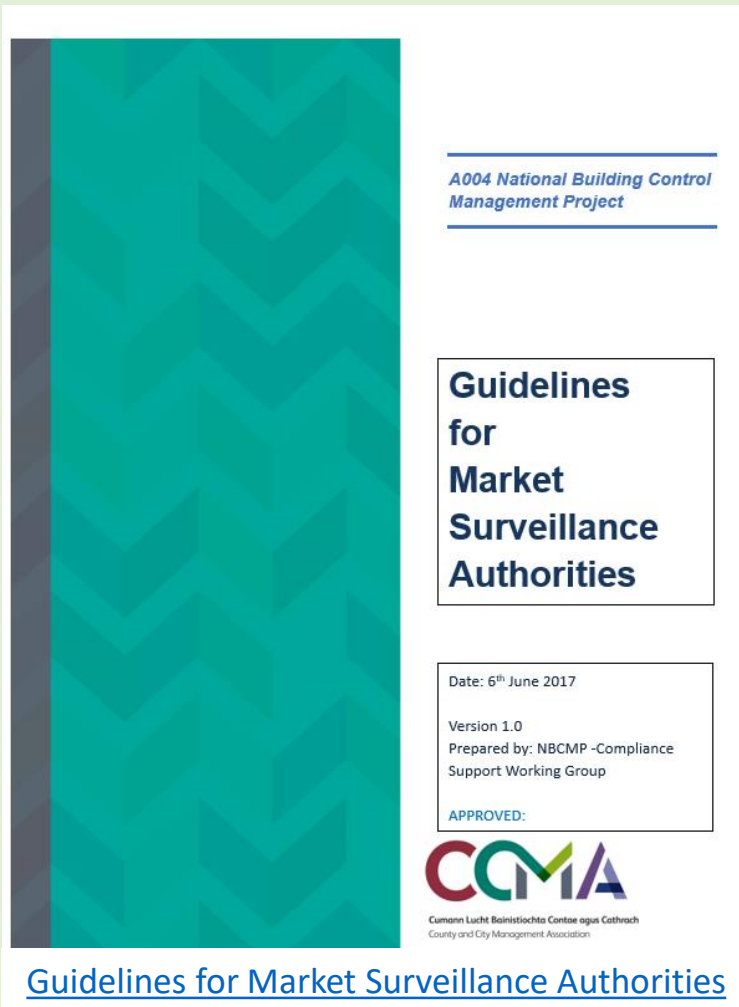

[Guidelines for Market Surveillance Authorities](#)

An Roinn Tithíochta,  
Pleanála agus Rialtais Áitiúil  
Department of Housing,  
Planning and Local Government



An tAire do Thithíocht agus Forbairt Uirbeach  
Minister for Housing and Urban Development

28<sup>th</sup> March 2019

Ms Mairead Phelan  
National Building Control Office  
Local Government Shared Services Centre  
3 Place Street, Dublin 2

Dear Mairead,

I am pleased to appoint you as an "authorised person" in accordance with Section 11 of the Building Control Act 1990 – 2014.

I am also pleased to appoint you as an "authorised officer" in accordance with European Union (Construction Products) Regulations 2013 (S.I. 225 2013).

I would like to take this opportunity to wish you success in your role as Manager of the National Building Control Office.

Yours sincerely,

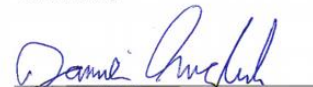
  
Damien English T.D.  
Minister for Housing and Urban Development

Please note: I am a Designated Public Official under the Regulation of Lobbying Act, 2015



## REGULATION (EU) 2019/1020- Article 11-Activities of Market Surveillance Authorities



- **Formal** compliance (administrative requirements e.g., documentation, markings, etc.) and '
- **Technical** compliance (essential characteristics requirements). Checks for Formal

### Compliance Checks & Inspections

- **Active:** Planned routine activities in a defined period targeting a number of specified products concentrated where:
  - risks are higher
  - non-compliance is more frequent
- **Reactive:** Responding to allegations of non-compliance and involves various levels of investigation – [support@nbco.gov.ie](mailto:support@nbco.gov.ie)
- **Random Inspections:** Making economic operators aware of the MSA presence in the marketplace – Market Surveillance Campaign for Aggregates 2021/22/23

**General Activities:** Regularly visit premises and workplaces where products are in service

- Random spot checks
- Take samples and test
- Incorporating material on EU Regulations (EU) No. 305/2011 on websites, including contact details for the authorised officers
- Review information regularly - establish a database which could assist the planning of future market surveillance activity

### Training & Promoting Compliance:

- Economic Operators
- Market Surveillance Authorities & competent National Authorities
- End-Users
- Others

## Regulation 2019/1020 CHAPTER V Article 14-MARKET SURVEILLANCE POWERS AND MEASURES

### Powers of market surveillance authorities

### OECD Regulatory Compliance –Enforcement

- “**enforcement**” covers all activities aimed at promoting compliance and reaching regulations’ outcomes: information and prevention, **inspections**, and enforcement actions in the narrower sense (i.e. improvement notices, fines, prosecutions etc.) arising in connection with regulatory inspections by authorised officials or agencies.
- “**Inspections**” covers any type of visit or check conducted by authorised officials on products or business premises, activities, documents etc. The way inspections are planned, better targeting, communicating with regulated subjects.

*Responsibility for enforcing Union harmonisation legislation should lie with the Member States & MSAs*

**Balance between Regulations** and removing unnecessary burdens on business community and citizens-well formulated enforcement strategy providing correct incentives. Organisation and governance of inspections. While inspections are sector specific there are many core activities that are universal for most sectors where inspections take place.

## National Market Surveillance Strategy

### Regulation EU 2019/1020 Article 13 National Market Surveillance Strategies.

Each Member State **shall draw** up an overarching national market surveillance strategy, at least every four years – [1<sup>st</sup> Strategy 16<sup>th</sup> July 2022](#).

Promote a consistent, comprehensive and integrated approach to market surveillance and to the enforcement-consider all stages of the product supply chain, ..imports and digital supply chains,-including priorities.

Include at least the following elements:

- available information on the occurrence of non-compliant products, --market trends that may affect non-compliance rates for products, and possible threats and risks related to emerging technologies;
- the areas identified by the Member States as priorities for the enforcement;
- enforcement activities planned to reduce non-compliance in identified priority areas;
- an assessment of the cooperation with Member State MSAs.

Configuration of the Regional Assemblies in Ireland



***Member States shall communicate their national market surveillance strategy to the Commission and other Member States through the information and communication system. Each Member State shall publish a summary of its strategy***

# National Market Surveillance Strategy

## Regulation EU 2019/1020 Article 13 National Market Surveillance Strategies

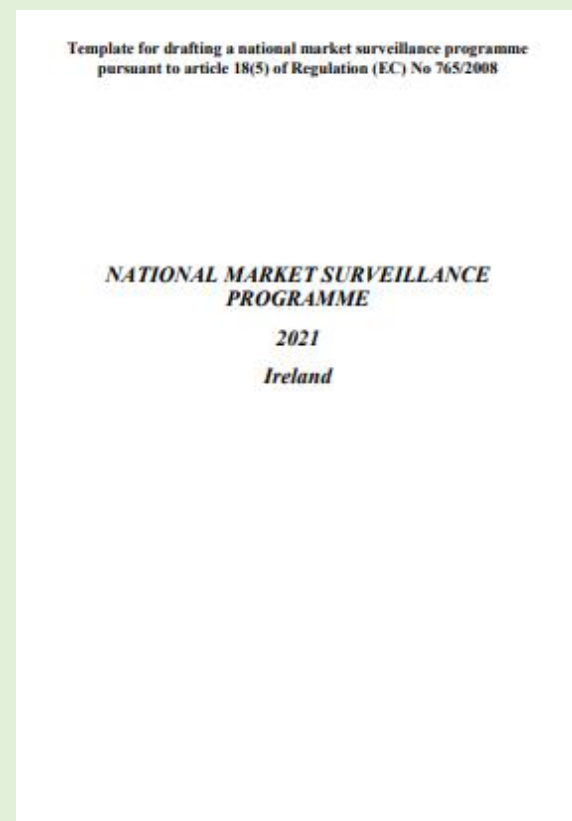

**Member States shall communicate their national market surveillance strategy to the Commission and other Member States through the information and communication system. Each Member State shall publish a summary of its strategy**

# National Market Surveillance Strategy 2023 Market Surveillance Planned/Proactive Activities Regulation EU 2019/1020 Article 13 National Market Surveillance Strategies 2023 contd.

**Construction products generated from quarries and pits, specifically products from Area Code 24 (Aggregates) of the CPR with a particular focus on:**

Article 13 of Regulation 2019/1020, Regulation ANNEX I List of Union harmonisation legislation  
38. Regulation (EU) No 305/2011 of the European Parliament and of the Council of 9 March 2011 laying down harmonised conditions for the marketing of construction products and repealing Council Directive 89/106/EEC (OJ L 88, 4.4.2011, p. 5).

- Construction Products
  - Date: 1<sup>st</sup> of January 2023
  - Dublin City Council - National Building Control and Market Surveillance Office

Table of Contents

1. Details of your organisation and responsibilities.....	2
1.1 Sector – Construction.....	2
1.1.1 Responsible authority and contact details.....	2
2. Relevant background information.....	2
2.1 Overview.....	2
2.2 Legislation & Competent Market Surveillance Authorities.....	3
2.3 Authorised Officers.....	3
2.4 2021 Market Surveillance Programme Report from Activities Conducted.....	3
2.5 2022 Market Surveillance Programme Report from Activities Conducted.....	5
3. Activities and Initiatives.....	5
3.1 Monitoring and Surveillance Activities.....	6
3.1.1 Market Screening Exercise.....	6
3.1.2 Approach for Setting Priorities.....	6
3.1.3 Risk Evaluation.....	6
3.1.4 Measures/tools for alerting users of hazardous products.....	6
3.1.5 Approach to Penalties.....	7
3.1.6 2023 Market Surveillance Planned/Proactive Activities.....	7
3.1.7 2023 Market Surveillance Reactive Activities.....	7
4. Monitoring, evaluation, and Indicators.....	8
4.1 Products Presenting a Serious Risk.....	8
4.2 Tangible Indicators Market Surveillance of Construction Products under S.I. 225 of 2013.....	8
5. Cooperation between Member States.....	9
5.1 Active Liaison, Advice and Guidance.....	9
5.2 Co-operation.....	9
5.3 Horizontal Co-operation.....	9
5.4 Informing undertakings.....	9

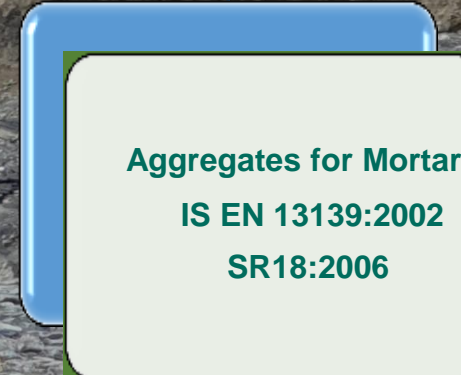
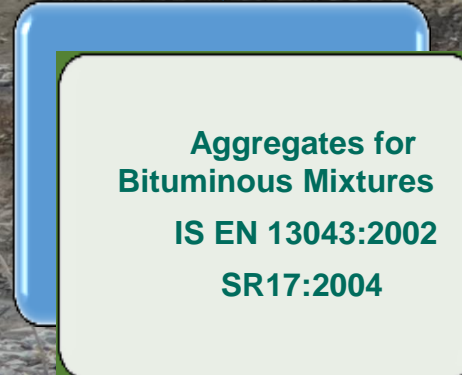
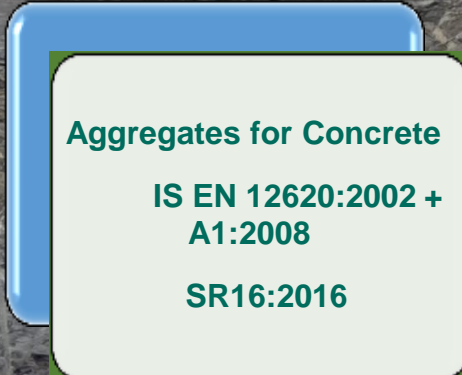
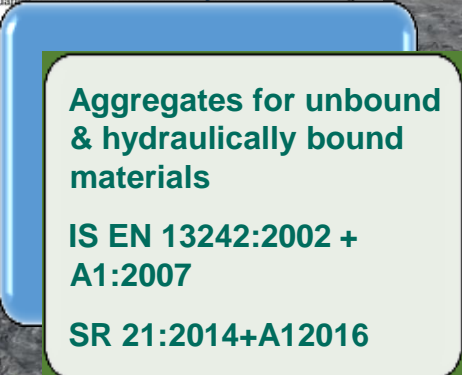
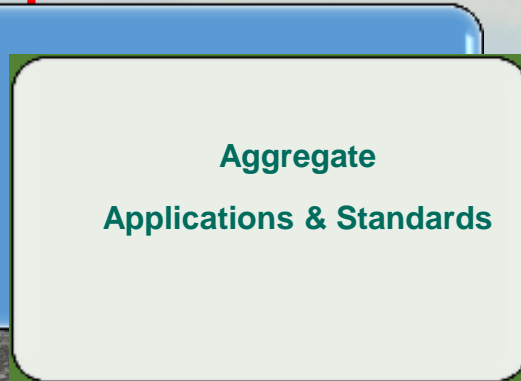

# Formal Compliance Requirements

## Formal Compliance Requirements (minimum)

[Regulation 305/2011 CHAPTER II DECLARATION OF PERFORMANCE AND CE MARKING](https://eur-lex.europa.eu/legal-content/EN/TXT/?uri=celex%3A32011R0305)

<https://eur-lex.europa.eu/legal-content/EN/TXT/?uri=celex%3A32011R0305>

Declaration of Performance (DoP)	CE Marking	Safety Information in Use
Unique identification code of the product-type	Is the CE marking followed by the two last digits of the year in which it was first affixed	When making a construction product available on the market, manufacturers/importers/distributors shall ensure that the product is accompanied by instructions and safety information in a language determined by the Member State concerned which can be easily understood by users.
Date of the declaration of performance	Name and address of the manufacturer details	
Name and address of the manufacturer details	Unique identification code of the product-type	
Is there a reference number of the declaration of performance (DoP)?	Is there a reference number of the declaration of performance (DoP)	
Is the declared performance in accordance with Annex ZA of the harmonised standard)	Is there a reference to the harmonised specification	
Is there a reference to the harmonised specification	Is there an identification number of the notified body	
Identification number of the notified body	Is the intended use available	
System of AVCP		
Which AVCP system is applied		
Is the intended use available		

**'CE marking'** shall mean a marking by which the manufacturer indicates that the product is in conformity with the applicable requirements set out in Community harmonisation legislation providing for its affixing; The CE marking should be affixed to all construction products for which the manufacturer has drawn up a declaration of performance in accordance with this Regulation. If a declaration of performance has not been drawn up, the CE marking should not be affixed.

By drawing up the declaration of performance, the manufacturer shall assume responsibility for the conformity of the construction product with such declared performance. In the absence of objective indications to the contrary, Member States shall presume the declaration of performance drawn up by the manufacturer to be accurate and reliable.

## Article 59-Regulation

**305/2011 prescribes** the requirements for “*formal non-compliance*” and requires that where a Member State makes **one of the following findings**, it shall require the relevant economic operator to put an end to the non-compliance concerned, i.e., the CE marking has been affixed in breach of Article 8 or 9; **or** the CE marking has not been affixed, when required, in accordance with Article 8(2); **and/or** the declaration of performance has not been drawn up, when required, in accordance with Article 4; **or** the declaration of performance has not been drawn up in accordance with Articles 4, 6 and 7; **and/or** the technical documentation is either not available or not complete.

Article 8-The CE marking shall be affixed to those construction products for which the manufacturer has drawn up a declaration of performance in accordance with Articles 4 and 6.

# Information Note to Economic Operators

## Phase 1

Raise Awareness  
May/June 2023

Phase 2  
Planning visits to Premises/ ICSMS  
July/ December 2023

Phase 3  
Conclusion  
December 2023

### Market Surveillance Campaign 2023

Aggregate Products within the scope of EN 12620, EN 13043, EN13139 and EN 13242 series must be CE Marked,



If you are an Economic Operator:

- E.g.
- Manufacturer;
  - Importer; or
  - Retailer / Distributor

of aggregates products you should be aware of your obligations under the rules for CE Marking.

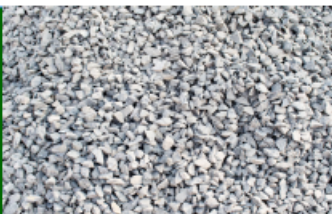

The National Building Control and Market Surveillance Office (NBCMSO) is the approved office for market surveillance in relation to construction products. Over the coming weeks, the NBCMSO will be carrying out unannounced inspections of quarries to check the CE Marking of aggregate products including those within the scope of EN 12620, EN 13043, EN13139 and EN 13242.

The objective of the Market Surveillance Office is to ensure that only products compliant with the Construction Products Regulation (EU) No 305/2011, are placed on the market.

If you receive a visit, the Market Surveillance Office may check that you have applied the CE Marking correctly, that you have all the required documentation in place (see overleaf) and may take a sample away for testing. Anybody obstructing, impeding or providing false information to the Authorised Officer may be committing an offence under the EU CPR.

The Market Surveillance Campaign 2023 is co-ordinated by Dublin City Council - National Building Control Office (DCC-NBCO).



➤ Powers of Inspection

➤ What's Required?

➤ Time for Compliance

➤ Corrective Action

➤ Penalties

➤ Further Information

### What happens if I receive a visit from the Market Surveillance Authority?

#### 1. GENERAL

If you receive a visit, from an Authorised Officer, in exercise of the powers conferred on the Authorised Officer by Regulation 12(3) of the European Union (Construction Products) Regulations 2013, the information outlined in Table 1 below can be requested for inspection, having regard to the responsibility you have under the Construction Products Regulation No. (EU) 305/2011.

**Table 1: Information sought (but not limited to) relevant to the responsibility of each Economic Operator**

No.	Description	Manufacturer	Importer	Distributor/ Retailer
1.	A copy / photograph of the CE mark	Y	Y	Y
2.	A Valid Declaration of Performance (DoP)	Y	Y	Y
3.	The technical documentation to support that the product complies with the requirements of EN 12620, EN 13043, EN 13242 and EN 13139.	Y	Y	Y
4.	The test reports and details in respect of type testing of the product.	Y	-	-
5.	Details of the notified factory production control certification body (AVCP System 2+).	Y	-	-
6.	The means by which products within the scope of EN 12620, EN 13043, EN13139 and EN 13242 are placed, or made available, on the market can be identified and traced throughout the supply chain.	Y	Y	Y

#### 2. TIME FOR COMPLIANCE

The information sought should be readily available onsite. CE Marking of construction products is mandatory across the EU since 1 July 2013.

#### 3. TAKE NOTICE

In the event that the required documentation is not available at time of inspection or on request for information, you may make representations in writing to the Market Surveillance Authority within 14 days. The Market Surveillance Authority may, having considered any such representations, amend the terms of this request for information or confirm or revoke the request for information.

#### 4. TAKE FURTHER NOTICE

If you, the Economic Operator: -

- a) do not comply with the terms of a request for information within the aforementioned period or
- b) the documentation submitted/ made available on the date of visit, is not in compliance with the Construction Products Regulation.

the Market Surveillance Authority may take such steps as it considers reasonable and necessary to secure compliance with the request for information under the Construction Products Regulation, up to and including prosecution through the Courts.

#### 5. WARNING

A person guilty of an offence under the European Union (Construction Products) Regulations 2013 is liable: -

- a) on summary conviction to a fine up to €5,000 or to a term of imprisonment up to 3 months or to both; or
- b) on conviction on indictment to a fine up to €500,000 or to a term of imprisonment up to 12 months or both.

#### 6. ADDITIONAL INFORMATION

- Regulation No (EU) 305/2011 <http://eur-lex.europa.eu/LexUriServ/LexUriServ.do?uri=OJ.L.2011.088.0005.0043.EN.PDF>
- European Union (Construction Products) Regulations 2013 <http://www.irishstatelibrary.ie/2013/en/si/0225.html>
- CE Marking of Construction Products—Step by Step
- EN 12620:2002+A1:2008 Aggregates for concrete, EN 13043:2002/AC:2004 Aggregates for bituminous mixtures and surface treatments for roads, airfields and other trafficked areas or EN 13242:2002+A1:2007 Aggregates for unbound and hydraulically bound materials for use in civil engineering work and road construction
- SR 16:2016 – Guidance on the use of I.S. EN 12620:2002 - Aggregates for Concrete, SR 17:2004 Guidance on the



# National Market Surveillance Strategy 2023 Market Surveillance Planned/Proactive Activities

## Regulation EU 2019/1020 Article 13 National Market Surveillance Strategies 2023 contd.

Article 13 of Regulation 2019/1020, Regulation ANNEX I list of Union harmonisation legislation, 38. Regulation (EU) No 305/2011 of the European Parliament and of the Council of 9 March 2011 laying down harmonised conditions for the marketing of construction products and repealing Council Directive 89/106/EEC (OJ L 88, 4.4.2011, p. 5).

- Construction Products
- Date: 1<sup>st</sup> of January 2023
- Dublin City Council - National Building Control and Market Surveillance Office

Table of Contents

- 1. Details of your organisation and responsibilities .....2
  - 1.1 Sector – Construction .....2
    - 1.1.1 Responsible authority and contact details .....2
- 2. Relevant background information .....2
  - 2.1 Overview .....2
  - 2.2 Legislation & Competent Market Surveillance Authorities .....3
  - 2.3 Authorised Officers .....3
  - 2.4 2021 Market Surveillance Programme Report from Activities Conducted .....3
  - 2.5 2022 Market Surveillance Programme Report from Activities Conducted .....5
- 3. Activities and Initiatives .....5
  - 3.1 Monitoring and Surveillance Activities .....6
    - 3.1.1 Market Screening Exercise .....6
    - 3.1.2 Approach for Setting Priorities .....6
    - 3.1.3 Risk Evaluation .....6
    - 3.1.4 Measures/tools for alerting users of hazardous products .....6
    - 3.1.5 Approach to Penalties .....7
    - 3.1.6 2023 Market Surveillance Planned/Proactive Activities .....7
    - 3.1.7 2023 Market Surveillance Reactive Activities .....7
- 4. Monitoring, evaluation, and Indicators .....8
  - 4.1 Products Presenting a Serious Risk .....8
  - 4.2 Tangible Indicators Market Surveillance of Construction Products under S.I. 225 of 2013 ..8
- 5. Cooperation between Member States .....9
  - 5.1 Active Liaison, Advice and Guidance .....9
  - 5.2 Co-operation .....9
  - 5.3 Horizontal Co-operation .....9
  - 5.4 Informing undertakings: .....9

### a. Structural Steel & Aluminium (EN1090)

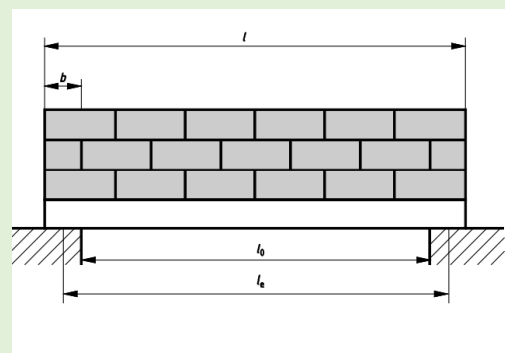
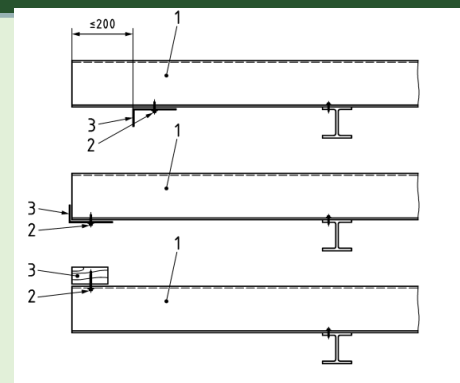

### b. Lintels (EN 845-2)

### c. Wall Ties, Tension Straps, Hangers, and Brackets (EN 845-1)

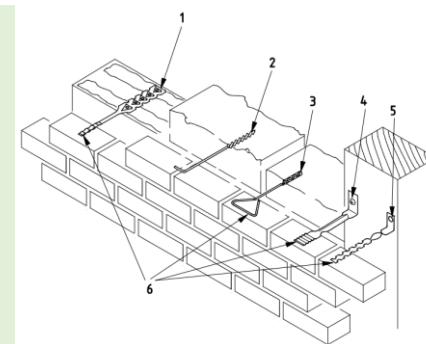

**Member States shall communicate their national market surveillance strategy to the Commission and other Member States through the information and communication system. Each Member State shall publish a summary of its strategy**

# National Market Surveillance Strategy 2023 Market Surveillance Reactive Activities

## Regulation EU 2019/1020 Article 13 National Market Surveillance Strategies 2023 contd.



Article 13 of Regulation 2019/1020, Regulation ANNEX I List of Union harmonisation legislation.  
38. Regulation (EU) No 305/2011 of the European Parliament and of the Council of 9 March 2011 laying down harmonised conditions for the marketing of construction products and repealing Council Directive 89/105/EEC (OJ L 88, 4.4.2011, p. 5).

- Construction Products
- Date: 1<sup>st</sup> of January 2023
- Dublin City Council - National Building Control and Market Surveillance Office

Table of Contents

- 1. Details of your organisation and responsibilities .....2
  - 1.1 Sector – Construction .....2
    - 1.1.1 Responsible authority and contact details .....2
- 2. Relevant background information .....2
  - 2.1 Overview .....2
  - 2.2 Legislation & Competent Market Surveillance Authorities .....3
  - 2.3 Authorised Officers .....3
  - 2.4 2021 Market Surveillance Programme Report from Activities Conducted .....3
  - 2.5 2022 Market Surveillance Programme Report from Activities Conducted .....5
- 3. Activities and Initiatives .....5
  - 3.1 Monitoring and Surveillance Activities .....6
    - 3.1.1 Market Screening Exercise .....6
    - 3.1.2 Approach for Setting Priorities .....6
    - 3.1.3 Risk Evaluation .....6
    - 3.1.4 Measures/tools for alerting users of hazardous products .....6
    - 3.1.5 Approach to Penalties .....7
    - 3.1.6 2023 Market Surveillance Planned/Proactive Activities .....7
    - 3.1.7 2023 Market Surveillance Reactive Activities .....7
- 4. Monitoring, evaluation, and Indicators .....8
  - 4.1 Products Presenting a Serious Risk .....8
  - 4.2 Tangible Indicators Market Surveillance of Construction Products under S.I. 225 of 2013 ..8
- 5. Cooperation between Member States .....9
  - 5.1 Active Liaison, Advice and Guidance .....9
  - 5.2 Co-operation .....9
  - 5.3 Horizontal Co-operation .....9
  - 5.4 Informing undertakings: .....9

In 2023, reactive market surveillance inspections/enforcement will continue to be carried out, triggered on foot of:

- acting on information received from **complaints**, or
- in relation to a specific **suspected offence** or
- through **RAPEX** or
- **ICSMS**, and
- notifications from **other authorities**.

Configuration of the Regional Assemblies in Ireland



**Member States shall communicate their national market surveillance strategy to the Commission and other Member States through the information and communication system. Each Member State shall publish a summary of its strategy**

# National Market Surveillance Strategy tangible Market Surveillance indicators

## Regulation EU 2019/1020 Article 13 National Market Surveillance Strategies 2023 contd.

**Article 13 of Regulation 2019/1020, Regulation ANNEX I List of Union harmonisation legislation, 38. Regulation (EU) No 305/2011 of the European Parliament and of the Council of 9 March 2011 laying down harmonised conditions for the marketing of construction products and repealing Council Directive 89/109/EEC (OJ L 88, 4.4.2011, p. 5).**

- Construction Products
- Date: 1<sup>st</sup> of January 2023
- Dublin City Council - National Building Control and Market Surveillance Office

Table of Contents

- 1. Details of your organisation and responsibilities.....2
  - 1.1 Sector – Construction.....2
    - 1.1.1 Responsible authority and contact details.....2
- 2. Relevant background information.....2
  - 2.1 Overview.....2
  - 2.2 Legislation & Competent Market Surveillance Authorities.....3
  - 2.3 Authorised Officers.....3
  - 2.4 2021 Market Surveillance Programme Report from Activities Conducted.....3
  - 2.5 2022 Market Surveillance Programme Report from Activities Conducted.....5
- 3. Activities and Initiatives.....5
  - 3.1 Monitoring and Surveillance Activities.....6
    - 3.1.1 Market Screening Exercise.....6
    - 3.1.2 Approach for Setting Priorities.....6
    - 3.1.3 Risk Evaluation.....6
    - 3.1.4 Measures/tools for alerting users of hazardous products.....6
    - 3.1.5 Approach to Penalties.....7
    - 3.1.6 2023 Market Surveillance Planned/Proactive Activities.....7
    - 3.1.7 2023 Market Surveillance Reactive Activities.....7
- 4. Monitoring, evaluation, and Indicators.....8
  - 4.1 Products Presenting a Serious Risk.....8
  - 4.2 Tangible Indicators Market Surveillance of Construction Products under S.I. 225 of 2013...8
- 5. Cooperation between Member States.....9
  - 5.1 Active Liaison, Advice and Guidance.....9
  - 5.2 Co-operation.....9
  - 5.3 Horizontal Co-operation.....9
  - 5.4 Informing undertakings.....9

Market Surveillance of Construction Products under S.I. 225 of 2013 Indicators to end of year	2021	2022	2023
1. Total No. of construction product related complaints	10	4	2
2. No. of formal complaints by industry concerning unfair competition	0	1	0
3. Total No. of inspections and broken down by:			
i. No. of reactive inspections undertaken on foot of complaint,	10	2	0
ii. No. of on-site self-initiated inspections	109	70	7
iii. No. of desk-top self-initiated inspections, and	109	70	7
iv. No. of inspections prompted by the Revenue Commissioners (i.e., Customs)	0	0	0
4. Assessment of product compliance based on:			
i. Tests performed in laboratories	148	257	6
ii. Checks of products and/or documentation e.g., CE Mark, DoP, Safety Information in Use	109	70	4
5. No. of inspections/ assessments resulting in:			
i. A finding of non-compliance	2	3	0
ii. Corrective actions being taken by relevant economic operator (i.e., voluntary measures)	2	2	0
iii. Restrictive measures being taken by the market surveillance authority	2	1	0
iv. No of ICSMS Inspections logged	45	26	10
v. No of Article 12(3) of the EU (CPR) 2013 Requests for Information	32	70	7
vi. No of Article 14(1) of the EU (CPR) 2013 Notices Issued/Served	6	3	0
vii. No of Article 14(2) of the EU (CPR) 2013 Notices Issued/Served	0	0	0
viii. No of Article 14(3) of the EU (CPR) 2013 Notices Issued/Served	0	0	0
6. No of prosecutions taken	0	0	0
7. No. of successful prosecutions i.e., where sanctions/penalties were applied	0	0	0
8. No. of notifications to other Member State Market Surveillance Authorities	0	0	1
9. Additional Comments/Other	N/A	N/A	N/A

Configuration of the Regional Assemblies in Ireland



**Member States shall communicate their national market surveillance strategy to the Commission and other Member States through the information and communication system. Each Member State shall publish a summary of its strategy**

## Article 29 CHAPTER VIII COORDINATED ENFORCEMENT AND INTERNATIONAL COOPERATION

### Union Product Compliance Network

The purpose of the Network is to serve as a platform for structured coordination and cooperation between enforcement authorities of the Member States and the Commission, and to streamline the practices of market surveillance within the Union, thereby making market surveillance more effective.

The cover of the EUPCN Work Programme 2021-2022. It features a blue background with white text. The title "EUPCN WORK PROGRAMME 2021-2022" is prominently displayed. Below it, in smaller text, is the reference to the EU regulation. On the right side, there is a dark blue vertical bar with the text "Market Surveillance" in white.

#### EUPCN WORK PROGRAMME 2021-2022

REGULATION (EU) 2019/1020 OF THE EUROPEAN  
PARLIAMENT AND OF THE COUNCIL of 20 June 2019 on  
market surveillance and compliance of products and amending  
Directive 2004/42/EC and Regulations (EC) No 765/2008 and  
(EU) No 305/2011

Market Surveillance

# Regulation 2019/1020

## Article 32 Role and tasks of administrative cooperation groups (ADCOs)

1. ADCOs shall address specific matters related to market surveillance and sector specific issues.

2. ADCOs shall have the following tasks:

- (a) to facilitate the uniform application of Union harmonisation legislation within their area of competence with a view to increasing the efficiency of market surveillance throughout the internal market;
- (b) to promote communication between market surveillance authorities and the Network and develop mutual confidence between market surveillance authorities;
- (c) to establish and coordinate common projects, such as cross-border joint market surveillance activities;
- (d) to develop common practices and methodologies for effective market surveillance;
- (e) to inform each other of national market surveillance methods and activities and to develop and promote best practices;
- (f) to identify issues of shared interest relating to market surveillance and suggest common approaches to be adopted;
- (g) to facilitate sector-specific evaluations of products, including risk assessments, test methods and results, recent scientific developments and other aspects relevant to control activities.



The screenshot shows the European Commission website. The top navigation bar includes the European Commission logo, a language selector set to 'EN English', and a search box. Below the navigation bar is a blue header for 'Internal Market, Industry, Entrepreneurship and SMEs'. A secondary navigation bar contains links for 'Home', 'Single market and standards', 'Industry', 'Entrepreneurship and SMEs', 'Access to finance', 'Sectors', and 'Tools and databases'. The breadcrumb trail reads: 'Home > ... > Market surveillance for products > The implementation of market surveillance in Europe > Administrative Cooperation Groups (AdCos)'. The main heading is 'Administrative Cooperation Groups (AdCos)'. Below the heading, the text states: 'European cooperation on market surveillance takes place through informal groups of market surveillance authorities, called Administrative Cooperation Groups (AdCos)'.

[EU Login \(europa.eu\)](https://europa.eu)



# RAPEX, MSAs Role and Obligations

**Stage 5:** Risk assessment and RAPEX, Rapid Exchange of Information -rapid notification to market surveillance authorities.

- **Rapex Legal Basis:**

- Article 12 of Directive 2001/95/EC (GPSD)
- Article 20 of MSR (EU) 1020/2019 (Note Article 2(1) & Annex 1)

- **Application:**

- Non-food consumer products and non-consumer products
- Consumers and end-users
- Placed on market beyond territory of MS in Europe
- Measures are taking
- Article 19 MSR (EU 1020/2019) – products presenting a serious risk  
Risk Assessment key component (Art 19(2))
- Article 11 Directive 2001/95/EC (GPSD) – less than serious risk/Not placed on EU market
- Reactive follow-up notifications
- Timelines Important

- Weekly list published of non-compliant (dangerous) items.



[Commission Implementing Decision \(EU\) 2019/417 RAPEX](#)



A close-up photograph of a network switch or patch panel. Numerous white Ethernet cables are plugged into the ports, with some featuring yellow and blue RJ45 connectors. Several green status lights are illuminated, indicating active connections. The background is dark, making the white cables and green lights stand out. The text is overlaid on the center of the image.

# ICSMS

## Information and Communication System for Market Surveillance

### Summary

Market surveillance of products in the EU plays a crucial role in the protection of public interest, as even the best rules are worth little if they are not enforced properly. Market surveillance is also of interest for serious manufacturers, as it ensures a level playing field for reputable businesses. ICSMS was developed to facilitate the work of market surveillance authorities.

# Market Surveillance – Promoting Compliance

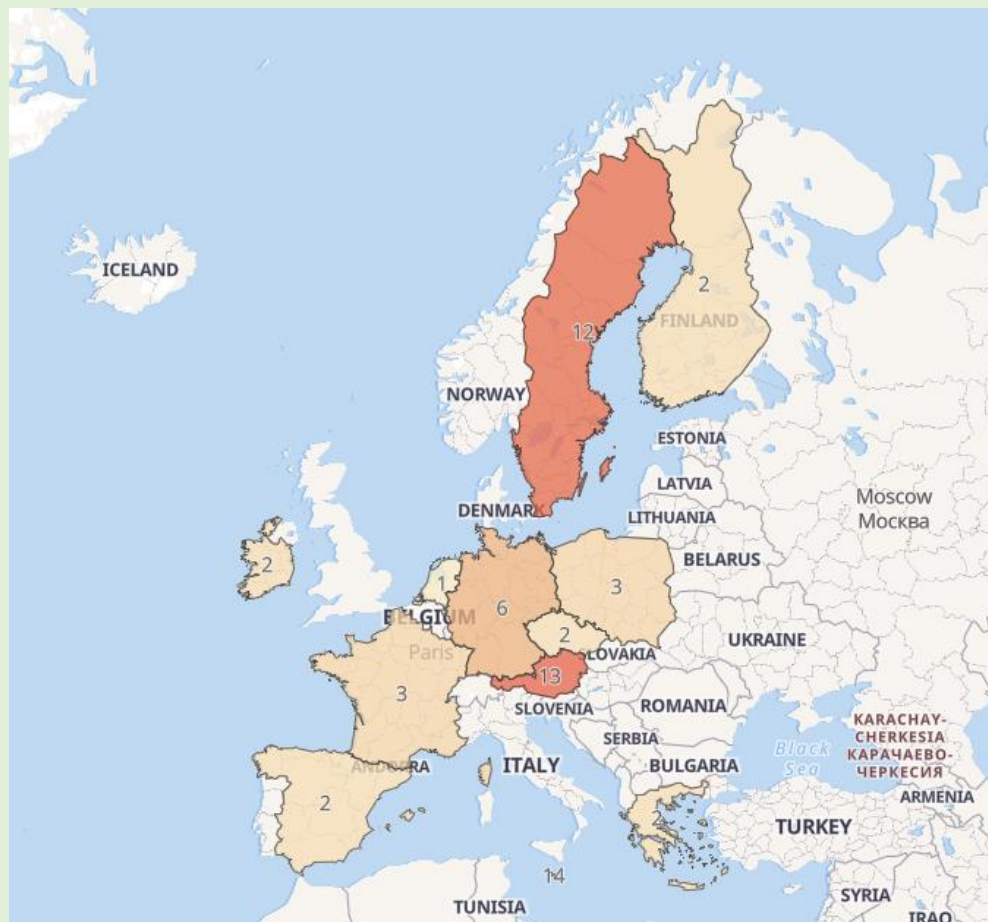

The "Addressee Countries - MAR" Visualization map represents the total number of Mutual Assistance Requests – 8th November 2022

## REGULATION (EU) 2019/1020

### CHAPTER VI

#### CROSS-BORDER MUTUAL ASSISTANCE

##### Article 22

##### Mutual Assistance

1. There shall be efficient cooperation and exchange of information among the market surveillance authorities of the Member States, and between market surveillance authorities and the Commission and the relevant Union agencies.
2. When a market surveillance authority is unable to conclude its investigation because of its inability to access certain information, despite having made all appropriate efforts to obtain that information, it may submit a reasoned request to the market surveillance authority of another Member State where access to this information can be enforced. In this case the requested authority shall supply to the applicant authority without delay and in any event within 30 days any information that the requested authority

RFEM | 230202100961 | IRL | 9400 - National Building Control & Market Surveillance Office

	Product name (English)	Distinction Door - Renown RE02
	Date of Creation	02/02/2023
	Type / Model	RE02
	Brand	Distinction Doors
	Product File Status	Not Completed
	Product File Compliance Status	Not compliant
	Product File Risk Level	
	Product File Visibility	EU/EFTA authorities
	Notifications	

Summary	Applicant	Request Details	Economic Operators	Addressee	Response Details
RFEM 4		Request Id			230202100961
RFEM 5		Status			Waiting for Response
RFEM 2		Applicant Authority		> [9400] National Building Control & Market Surveillance Office	
RFEM 19		Addressee Authority		> [10684] OPSS - Single Liaison Office	
RFEM 10		Enforcement Measure Requested			Market Surveillance Inspection
RFEM 13		Submission Date			02/02/2023
RFEM 27		Time remaining for prompt reply			75 days
RFEM 28		Timer paused			No

appropriate in order to  
stance of other market  
requested authority agrees  
paragraph 2 where:  
order to establish non-  
d substantially impair



## Market Surveillance Campaign 2021-2023

165 on-site  
Market Surveillance Inspections

>400 laboratory tests performed on samples

9 Corrective actions notices issued 14(1)

109 Requests for information 12(3)

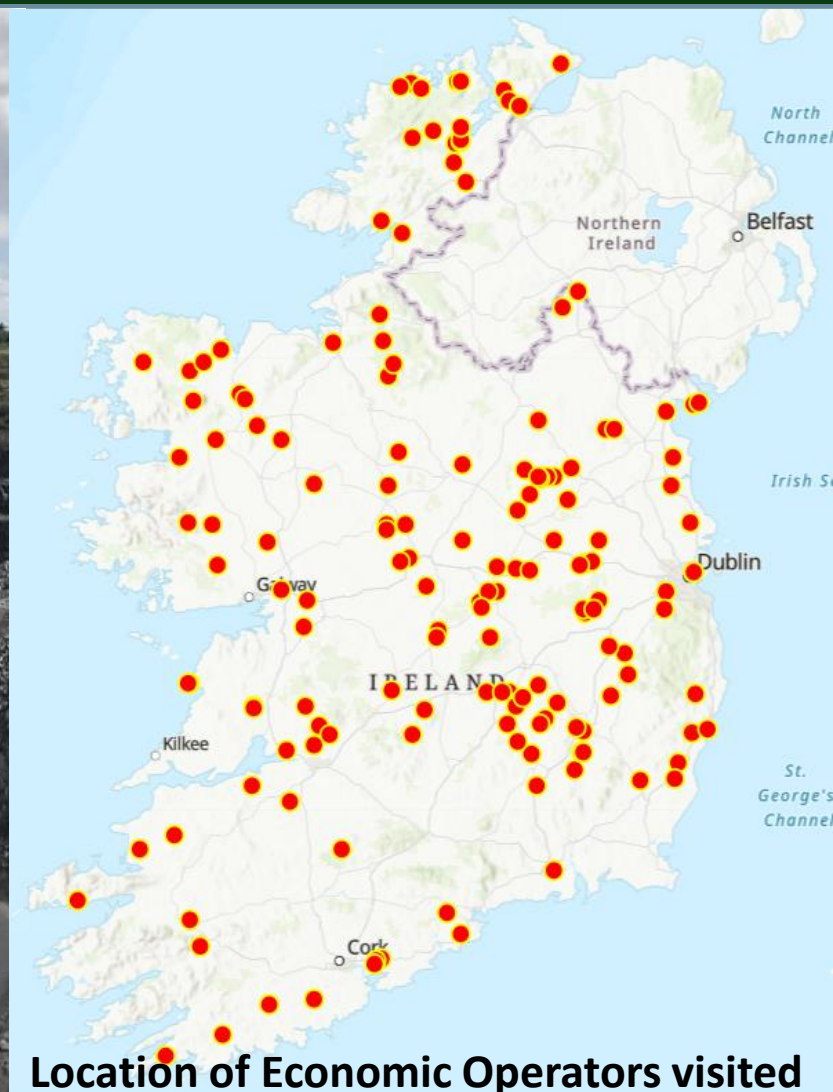

# Traceability-771-3 ref, SR 16

Examples of Traceability Procedures for block manufacturer		
File No.	System of Traceability	Acceptance
YYYYMMDD	Blocks stockpiled in the yard by production date. A form is completed that contains customer/location/production date/docket no, for each delivery. GPS	Accepted
YYYYMMDD	Strap numbers on each bale of blocks with documented strapping records.	Accepted
YYYYMMDD	Blocks stockpiled using batch codes. Unique batch code on each delivery docket.	Accepted
YYYYMMDD	Separate stockpiles for each production day. Stock control book populated with new stock. Each stockpile clearly identifiable.	Accepted
YYYYMMDD	Colour coded markings on each bale with a marked-up production calendar.	NC-Issued
YYYYMMDD	Strap numbers turned inside out with documented strapping records.	Accepted
YYYYMMDD	Dockets traced back to yard production date & storage location	Acceptance

**8.3.9 Traceability**-As appropriate, systems of traceability shall be given in the factory production control system.

**8.3.10 Nonconforming products** -The procedure for dealing with nonconforming products shall be documented. Products that do not conform with the requirements or the performance of the product type shall be segregated and marked accordingly. However, these products may be reassessed by the manufacturer and assigned to a different product type.

The manufacturer shall take action to avoid a reoccurrence of the nonconformity.

# Marking EN 771-3 –Delivery Dockets –key information

EN 771-3 is the core European Norm standard for concrete blocks and SR 325 is the national guidance for all things masonry, ref, <https://www.gov.ie/en/publication/45415-a-guide-to-the-marketing-and-use-of-aggregate-concrete-blocks-to-en-771-3-in-ireland/>

EN771-3, Section 7 and ZA.3 define the requirements for marking. ZA.1 and 2 define the info that should be in the DoP.

**7 Marking**-The following particulars shall be clearly marked on one of the following: the packaging, the delivery note, any certificate supplied with the masonry units, or 5 % of the units with a minimum of 4 per pack:

- a) the name, trademark or other means of identification of the manufacturer;
- b) means of identifying the date of manufacture of the units;
- c) means of identifying the units and relating them to their description and designation.

NOTE For CE marking and labelling, ZA.3 applies. Where ZA.3 requires the CE marking to be accompanied by the same information as required by this clause, the requirements of this clause can be considered to have been met.

# Traceability

Colour Coded-Straps Correctly Labelled EN ref,  
Name etc



No markings on strap



## Marking and stock control of products

The marking and stock control shall be documented.

Batches of products should be identifiable and traceable.

The manufacturer's inspection scheme for marking and stock control -VIP

# IS EN 12620

## *Aggregates for concrete*

IS EN 12620, (*Ref, SR 16 for guidance on use*)

### **9 Marking and labelling**

The delivery ticket shall contain **at least** the following information:

- a) designation;
- b) date of dispatch;
- c) serial number of the ticket;
- d) the number of this European Standard.

NOTE For CE marking and labelling see clause ZA.3 in annex ZA

*Note: IS888:2016 – Code of Practice for the procurement and use of unbound granular fill (hardcore) material for use under concrete floors and footpaths*

# IS EN 13242

*Aggregates for unbound and hydraulically bound materials for use in civil engineering work and road construction.*

IS EN 13242, (*Ref, SR 21 for guidance on use*)

### **10 Marking and labelling**

The delivery ticket shall contain **at least** the following information:

- a) designation;
- b) date of dispatch;
- c) serial number of the ticket;
- d) reference to this European Standard.

NOTE For CE marking and labelling see ZA.3.

# Marking & Labelling Raw Materials – Stockpiles – Prevent Contamination



**Making an Impression-  
Other Regulatory  
Compliance Issues!!!!**



## IS EN 13139

## IS EN 13043

### *Aggregates for mortar*

**IS EN 13139, (Ref, SR 18 for guidance on use)**

**10 Marking and labelling** -Each delivery of aggregate for mortar shall be accompanied by a numbered delivery ticket, issued by or on behalf of the producer, stating:

- a) source (name of pit or quarry or in case of doubt, also depot);
- b) the production rea and /or location;
- c) the date of dispatch;
- d) the designation in in accordance with Clause 9
- e)if required, the particle density and maximum chloride content;
- f)CE marking if relevant

Note I can be a requirement of the supply agreement to have additional information included on the delivery ticket

NOTE For CE marking and labelling see clause ZA.3

### *Aggregates for Bituminous Materials*

**IS EN 13043, (Ref, SR 18 for guidance on use)**

### **8 Marking and labelling**

The delivery ticket shall contain **at least** the following information:

- a) designation;
- b) date of dispatch;
- c) serial number of the ticket;
- d) reference to this European Standard.

NOTE For CE marking and labelling see ZA.3 in annex ZA.

# Silo segregation of different aggregates



- **Size Correctly-for production plant**
- **How long will raw materials be stored in the elements**
- **Emptying**
- **Leaching of fines**
- **Properly Labelled**





# No Segregation?? Contamination



How does  
anyone  
know what is  
going on???

# General dumping ground on arrival usually reflects quality of documentation in store



# 99% of block production and storage occurring outdoors



**Proper Stock Control Essential**  
**First in First Out**

**How Long Will these be Exposed to Freeze-Thaw/ Elements???**



**Older Blocks???**

# Websites??

## REGULATIONS

COMMISSION DELEGATED REGULATION (EU) No 157/2014

of 30 October 2013

on the conditions for making a declaration of performance on construction products available on a website

## ***"reasonably foreseeable conditions of use of the product concerned"***

**'risk'** means the combination of the probability of an occurrence of a hazard causing harm and the degree of severity of that harm;

(19) **'product presenting a risk'** means a product having the potential to affect adversely health and safety of persons in general, health and safety in the workplace, *protection of consumers*, the environment, public security and other public interests, protected by the applicable Union harmonisation legislation, *to a degree which goes beyond that considered reasonable and acceptable in relation to its intended purpose or under the normal or reasonably foreseeable conditions of use of the product concerned, including the duration of use and, where applicable, its putting into service, installation and maintenance requirements*;

(20) **'product presenting a serious risk'** means a product presenting a risk, for which, based on a risk assessment and taking into account the normal and foreseeable use of the product, the combination of the probability of occurrence of a hazard causing harm and the degree of severity of the harm is considered to require rapid intervention by the market surveillance authorities, including cases where the effects of the risk are not immediate;

(21) **'end user'** means any natural or legal person residing or established in the Union, to whom a product has been made available either as a consumer outside of any trade, business, craft or profession or as a professional end user in the course of its industrial or professional activities;

**information Economic Operators MUST have available for aggregate concrete blocks placed on the market?**

**Specifiers, Designers, Builders, Certifiers and END USERS?**



Riailtas na hÉireann  
Government of Ireland

<https://www.gov.ie/en/publication/45415-a-guide-to-the-marketing-and-use-of-aggregate-concrete-blocks-to-en-771-3-in-ireland/>

## A Guide to the Marketing and Use of Aggregate Concrete Blocks to EN 771-3 in Ireland

for manufacturers, importers, distributors, specifiers, designers, builders, certifiers and end users

Version 1.0 April 2022

**S.R. 325 & Technical Guidance Documents (TGDs)**

**WE HAVE READ THIS GUIDE!**

**I HAVE READ & UNDERSTAND THE TGDs & S.R. 325**

**I HAVE READ THIS GUIDE!**

**"I am a self-builder / builder who intends to build (self-build or contract build), a house in the Republic of Ireland  
What are my obligations?"**

# Intended (End) Use(s)?

# Way Forward

**Market Surveillance of Construction Products**

**Summary**

**Penalise those who disregard the Law**

**Building Industry Confidence**

**50 years lifespan**

**Promote a Culture of Compliance**



## SR 21 which I.S EN13242:2002+A1 2007 Guidance on the Use of AGGREGATES FOR UNBOUND AND HYDRAULICALLY BOUND MATERIALS FOR USE IN CIVIL ENGINEERING WORK AND ROAD CONSTRUCTION

Standard Recommendation  
S.R. 21:2014+A1:2016

### Guidance on the use of I.S. EN 13242:2002 +A1:2007 - Aggregates for unbound and hydraulically bound materials for use in civil engineering work and road construction

© NSAI 2016 No copying without NSAI permission except --

National Standards Authority of Ireland

NSAI is the state standardisation body set up under the National Standards Authority of Ireland Act 1996 to publish Irish Standards.

**Revisions**  
Irish Standards are updated by amendment or revisions from time to time. Users of Irish Standards should make sure that they possess the latest version.

NSAI's **tailored updating service** is designed to meet your precise needs and is therefore the most efficient and cost-effective way of keeping ahead. For more details on the tailored updating service see:

**Standards.ie**  
Tel: +353 1 857 67301

**Buying standards**  
NSAI and international publications can be accessed:  
- at [standards.ie](http://standards.ie)  
- by tel: +353 1 857 67301 or  
- email: [info@standards.ie](mailto:info@standards.ie)

IRISH STANDARD  
I.S. EN 13242:2002+A1:2007

ICS 91.100.15

AGGREGATES FOR UNBOUND AND HYDRAULICALLY BOUND MATERIALS FOR USE IN CIVIL ENGINEERING WORK AND ROAD CONSTRUCTION

National Standards Authority of Ireland  
Glasnevin, Dublin 9  
Ireland  
Tel: +353 1 907 3800  
Fax: +353 1 907 3838  
<http://www.nsi.ie>

Sales  
<http://www.standards.ie>

This Irish Standard was published under the authority of the National Standards Authority of Ireland and comes into effect on: 12 February 2008

### Product Failures

I.S. EN 13242:2002+A1:2007

Annex ZA (informative)

Clauses of this European Standard addressing essential requirements or other provisions of EU Directives

ZA.1 Scope and relevant characteristics

(E) This European Standard has been prepared under Mandate M/125 Aggregates given to CEN by the European Commission and the European Free Trade Association.

REPORT OF THE EXPERT PANEL ON CONCRETE BLOCKS  
June 2017



Click to add text

FeS2.

Geologist – Knowledge of Raw Material

Standard Recommendation  
S.R. 16:2016

### Guidance on the use of I.S. EN 12620:2002 +A1:2008 - Aggregates for concrete

© NSAI 2016 No copying without NSAI permission except as permitted by copyright law.

Question: \_\_\_\_\_

Scope: \_\_\_\_\_

Terms and definitions: \_\_\_\_\_

Requirements of I.S. EN 13242:2002+A1:2007:

General: \_\_\_\_\_

Specific requirements:

Aggregate sizes (4.2 of I.S. EN 13242:2002+A1:2007): \_\_\_\_\_

Moisture requirements: \_\_\_\_\_

Leakage (8.3 of I.S. EN 13242:2002+A1:2007): \_\_\_\_\_

Stability requirements - Resistance to breakage (8.4 of I.S. EN 13242:2002+A1:2007): \_\_\_\_\_

Level of conformity: \_\_\_\_\_

Test: \_\_\_\_\_

Production control: \_\_\_\_\_

Use of the new material (Annex C.3.4 of I.S. EN 13242:2002+A1:2007): \_\_\_\_\_

Sampling and testing (Annex C.3.5 of I.S. EN 13242:2002+A1:2007): \_\_\_\_\_

Labelling information: \_\_\_\_\_

The EU Construction Products Regulation: \_\_\_\_\_

Guidance for specifying aggregates for pipe bedding, haunching and bedding: \_\_\_\_\_

Guidance for specifying aggregates for back-filling of filler drains: \_\_\_\_\_

Guidance for specifying aggregates for general fill materials: \_\_\_\_\_

Guidance for specifying aggregates for unbound sub-bases for road: \_\_\_\_\_

Guidance for specifying aggregates for unbound granular fill (hardwearing) for floors and footpaths: \_\_\_\_\_

Annex B (informative) between S.R. 21:2002+A1:2007 and S.R. 21:2014+A1:2016: \_\_\_\_\_

Annex C (informative) between S.R. 21:2002+A1:2007 and S.R. 21:2014+A1:2016: \_\_\_\_\_

Annex D (informative) between S.R. 21:2002+A1:2007 and S.R. 21:2014+A1:2016: \_\_\_\_\_

Annex E (informative) between S.R. 21:2002+A1:2007 and S.R. 21:2014+A1:2016: \_\_\_\_\_

Annex F (informative) between S.R. 21:2002+A1:2007 and S.R. 21:2014+A1:2016: \_\_\_\_\_

Annex G (informative) between S.R. 21:2002+A1:2007 and S.R. 21:2014+A1:2016: \_\_\_\_\_

Annex H (informative) between S.R. 21:2002+A1:2007 and S.R. 21:2014+A1:2016: \_\_\_\_\_

Annex I (informative) between S.R. 21:2002+A1:2007 and S.R. 21:2014+A1:2016: \_\_\_\_\_

Annex J (informative) between S.R. 21:2002+A1:2007 and S.R. 21:2014+A1:2016: \_\_\_\_\_

Annex K (informative) between S.R. 21:2002+A1:2007 and S.R. 21:2014+A1:2016: \_\_\_\_\_

Annex L (informative) between S.R. 21:2002+A1:2007 and S.R. 21:2014+A1:2016: \_\_\_\_\_

Annex M (informative) between S.R. 21:2002+A1:2007 and S.R. 21:2014+A1:2016: \_\_\_\_\_

Annex N (informative) between S.R. 21:2002+A1:2007 and S.R. 21:2014+A1:2016: \_\_\_\_\_

Annex O (informative) between S.R. 21:2002+A1:2007 and S.R. 21:2014+A1:2016: \_\_\_\_\_

Annex P (informative) between S.R. 21:2002+A1:2007 and S.R. 21:2014+A1:2016: \_\_\_\_\_

Annex Q (informative) between S.R. 21:2002+A1:2007 and S.R. 21:2014+A1:2016: \_\_\_\_\_

Annex R (informative) between S.R. 21:2002+A1:2007 and S.R. 21:2014+A1:2016: \_\_\_\_\_

Annex S (informative) between S.R. 21:2002+A1:2007 and S.R. 21:2014+A1:2016: \_\_\_\_\_

Annex T (informative) between S.R. 21:2002+A1:2007 and S.R. 21:2014+A1:2016: \_\_\_\_\_

Annex U (informative) between S.R. 21:2002+A1:2007 and S.R. 21:2014+A1:2016: \_\_\_\_\_

Annex V (informative) between S.R. 21:2002+A1:2007 and S.R. 21:2014+A1:2016: \_\_\_\_\_

Annex W (informative) between S.R. 21:2002+A1:2007 and S.R. 21:2014+A1:2016: \_\_\_\_\_

Annex X (informative) between S.R. 21:2002+A1:2007 and S.R. 21:2014+A1:2016: \_\_\_\_\_

Annex Y (informative) between S.R. 21:2002+A1:2007 and S.R. 21:2014+A1:2016: \_\_\_\_\_

Annex Z (informative) between S.R. 21:2002+A1:2007 and S.R. 21:2014+A1:2016: \_\_\_\_\_

Annex ZA (informative) between S.R. 21:2002+A1:2007 and S.R. 21:2014+A1:2016: \_\_\_\_\_

Annex ZB (informative) between S.R. 21:2002+A1:2007 and S.R. 21:2014+A1:2016: \_\_\_\_\_

Annex ZC (informative) between S.R. 21:2002+A1:2007 and S.R. 21:2014+A1:2016: \_\_\_\_\_

Annex ZD (informative) between S.R. 21:2002+A1:2007 and S.R. 21:2014+A1:2016: \_\_\_\_\_

Annex ZE (informative) between S.R. 21:2002+A1:2007 and S.R. 21:2014+A1:2016: \_\_\_\_\_

Annex ZF (informative) between S.R. 21:2002+A1:2007 and S.R. 21:2014+A1:2016: \_\_\_\_\_

Annex ZG (informative) between S.R. 21:2002+A1:2007 and S.R. 21:2014+A1:2016: \_\_\_\_\_

Annex ZH (informative) between S.R. 21:2002+A1:2007 and S.R. 21:2014+A1:2016: \_\_\_\_\_

Annex ZI (informative) between S.R. 21:2002+A1:2007 and S.R. 21:2014+A1:2016: \_\_\_\_\_

Annex ZJ (informative) between S.R. 21:2002+A1:2007 and S.R. 21:2014+A1:2016: \_\_\_\_\_

Annex ZK (informative) between S.R. 21:2002+A1:2007 and S.R. 21:2014+A1:2016: \_\_\_\_\_

Annex ZL (informative) between S.R. 21:2002+A1:2007 and S.R. 21:2014+A1:2016: \_\_\_\_\_

Annex ZM (informative) between S.R. 21:2002+A1:2007 and S.R. 21:2014+A1:2016: \_\_\_\_\_

Annex ZN (informative) between S.R. 21:2002+A1:2007 and S.R. 21:2014+A1:2016: \_\_\_\_\_

Annex ZO (informative) between S.R. 21:2002+A1:2007 and S.R. 21:2014+A1:2016: \_\_\_\_\_

Annex ZP (informative) between S.R. 21:2002+A1:2007 and S.R. 21:2014+A1:2016: \_\_\_\_\_

Annex ZQ (informative) between S.R. 21:2002+A1:2007 and S.R. 21:2014+A1:2016: \_\_\_\_\_

Annex ZR (informative) between S.R. 21:2002+A1:2007 and S.R. 21:2014+A1:2016: \_\_\_\_\_

Annex ZS (informative) between S.R. 21:2002+A1:2007 and S.R. 21:2014+A1:2016: \_\_\_\_\_

Annex ZT (informative) between S.R. 21:2002+A1:2007 and S.R. 21:2014+A1:2016: \_\_\_\_\_

Annex ZU (informative) between S.R. 21:2002+A1:2007 and S.R. 21:2014+A1:2016: \_\_\_\_\_

Annex ZV (informative) between S.R. 21:2002+A1:2007 and S.R. 21:2014+A1:2016: \_\_\_\_\_

Annex ZW (informative) between S.R. 21:2002+A1:2007 and S.R. 21:2014+A1:2016: \_\_\_\_\_

Annex ZX (informative) between S.R. 21:2002+A1:2007 and S.R. 21:2014+A1:2016: \_\_\_\_\_

Annex ZY (informative) between S.R. 21:2002+A1:2007 and S.R. 21:2014+A1:2016: \_\_\_\_\_

Annex ZZ (informative) between S.R. 21:2002+A1:2007 and S.R. 21:2014+A1:2016: \_\_\_\_\_



- Market Surveillance of construction Products
  - Education & Training
  - Compliance Support
  - Inspections
- [support@nbco.gov.ie](mailto:support@nbco.gov.ie)

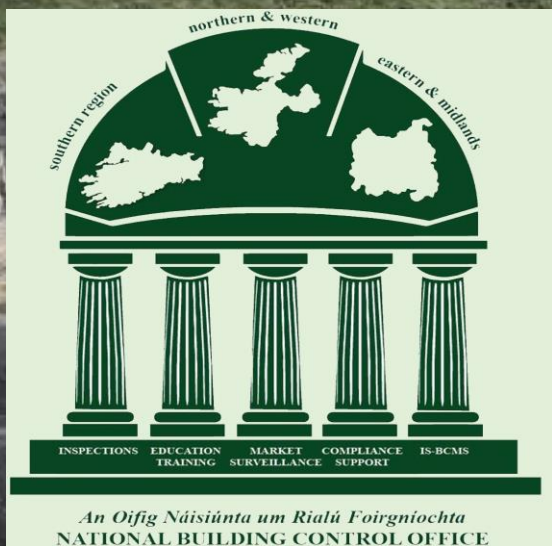

GO RAIBH  
MAITH  
AGAT



Website: [www.nbco.localgov.ie](http://www.nbco.localgov.ie)  
Twitter: [@NBCOIreland](https://twitter.com/NBCOIreland)  
YouTube: [NBCO DCC](https://www.youtube.com/NBCO DCC)